



HAFSA

Ovaj nosač monitora visokog kvaliteta, prati najnovije standarde u tehnologiji izrade nosača monitora. Dizajniran je tako da korisniku omogućava podešavanja po visini i uglovima gledanja. Ovo rezultira benefitom koji se ogleda u ergonomiji radnog prostora i očuvanju zdravlja zaposlenih. U ponudi su nosači monitora jednostruki i dvostruki u crnoj, beloj i sivoj boji.



VARIJANTE NOSAČA



DOSTUPNE BOJE



DIMENZIJE AMBALAŽE

	53cm	18cm	11cm	4kg
	62cm	24cm	12cm	6kg



10"-30"



VESA
75x75
100x100



Rotacija
360°



Nagib
-85~15°



Nosivost
Max 20kg



HAFSA

 DIMENZIJE

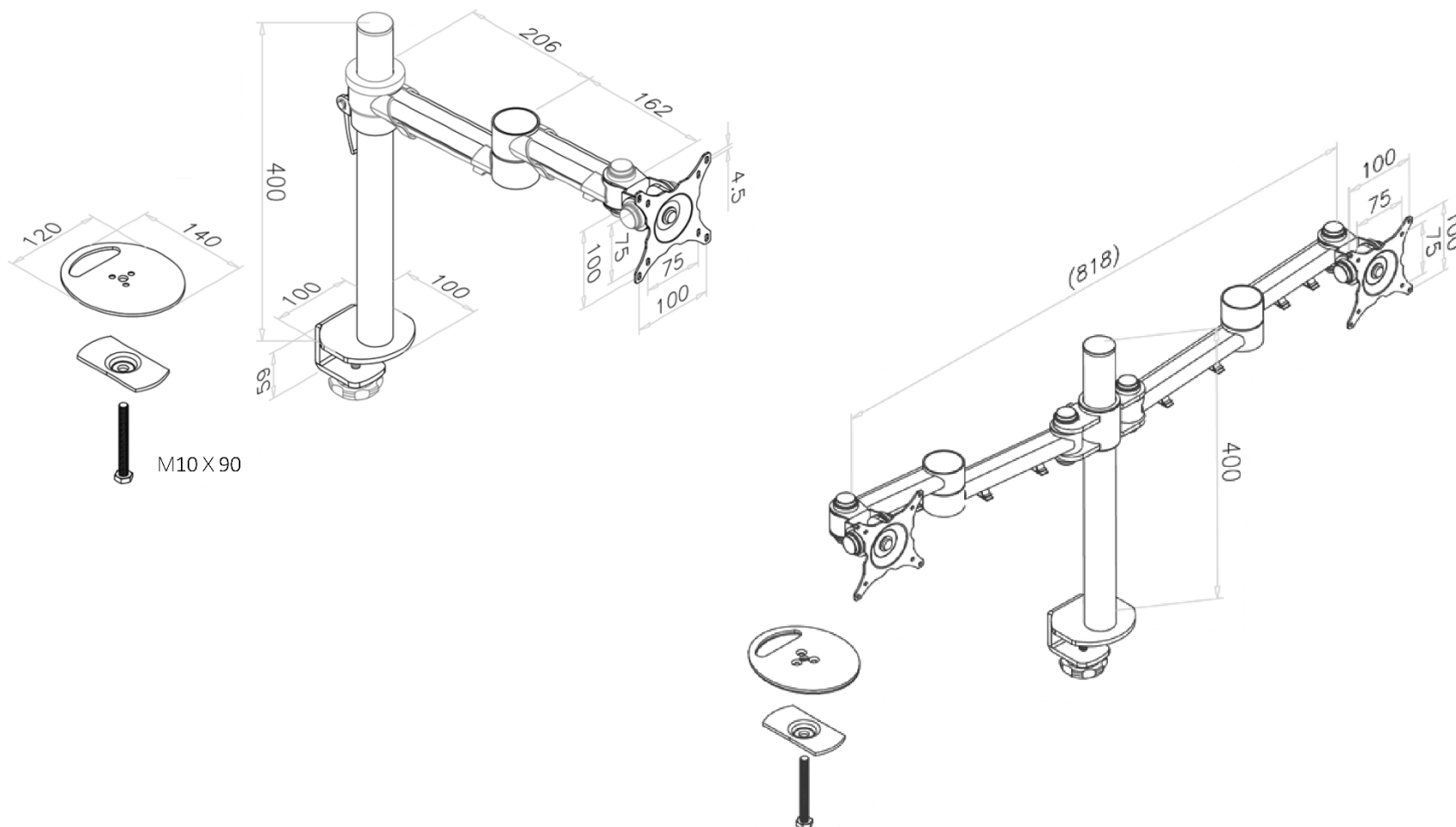











HAFSA



INSTALACIJA I KARAKTERISTIKE PROIZVODA

A  x1	B M6*25  x3	C 4 mm  x1	D  x2
E  x1	F  x8	G M4*10  x8	H 3 mm  x1

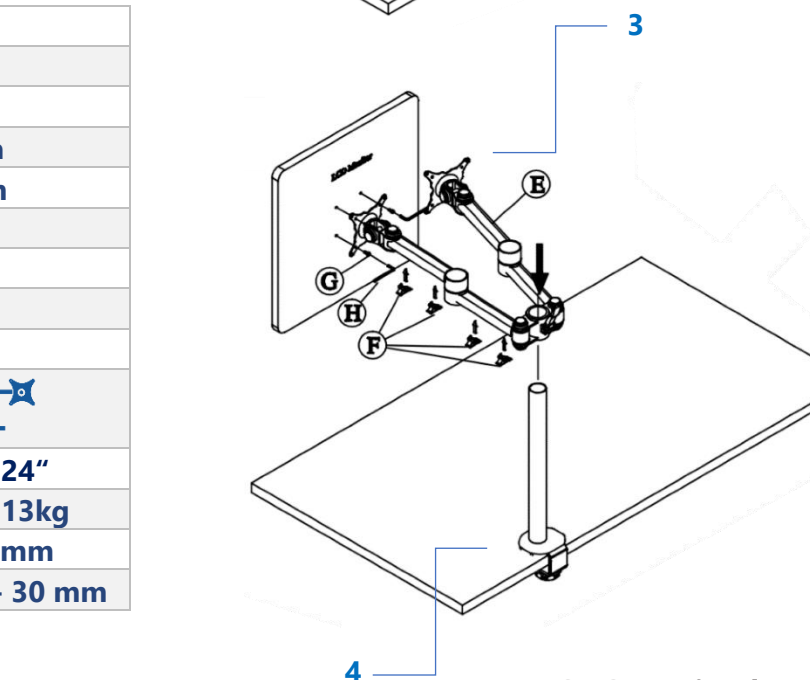
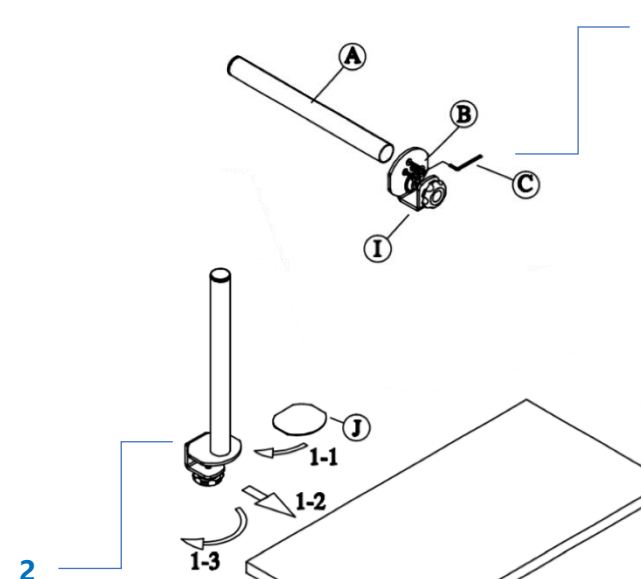

Kategorija proizvoda	Mehanički nosač	
Rang	Srednji	
Materijal	Čelik, aluminijum, plastika	
Boja	Mat crna, mat bela, srebrna	
Vesa kompatibilnost	75 x 75mm i 100 x 100 mm	
Nagib	80°	
Rotacija monitora	360°	
Instalacija	Pomoću stege ili kroz sto	
Kanalice za kablove	uključene	
		
Veličina monitora	Do 30"	Do 24"
Nosivost po ruci	max 20kg	max 13kg
Raspon ruku	455mm	818mm
Preporučena debljina ploče za stegu	10mm - 30 mm	10mm - 30 mm



